

## SB Series Simplex Basket Strainers

1/2" TO 4" PVC, CPVC, GFPP AND EASTAR®



PVC and CPVC only

### KEY FEATURES

- PVC, CPVC, GFPP and Eastar
- Ergonomic Hand-Removable Cover
- In-Line or Loop Connections
- External Cover Threads
- Integral Flat Mounting Bases
- NSF / ANSI 61 Listed

### OPTIONS

- Stainless Steel, Monel®, Hastelloy®, and Titanium Strainer Baskets
- Pressure Differential Gauge and Switch
- Baskets Available with Perforated or Mesh Liners

### MATERIALS

- PVC Cell Class 12454 per ASTM D1784
- CPVC Cell Class 23447 per ASTM D1784
- GFPP Cell Class 85580 per ASTM D4101
- Eastar
- FPM and EPDM O-Ring Seals

## TECHNICAL INFORMATION

### EXPLODED VIEW

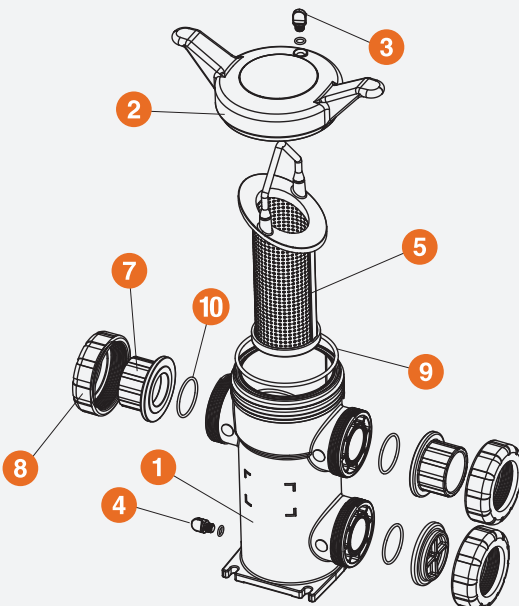

### SELECTION CHART

SIZE	MATERIAL	END CONNECTION	SEALS	PRESSURE RATING
1/2" – 4" (DN15 – DN100)	PVC, CPVC and GFPP	Socket, Threaded or Flanged	FPM or EPDM	150 PSI @ 70°F Non-Shock
	Eastar*			100 PSI @ 70°F Non-Shock

\* End connections and assembly nuts are PVC

# SB Series Simplex Basket Strainers

1/2" TO 4" PVC, CPVC, GFPP AND EASTAR®

## TECHNICAL INFORMATION, CONTINUED

### PARTS LIST

1. Body
2. Cover
3. Vent Plug and O-Ring
4. Drain Plug and O-Ring
5. Basket
6. Flange (Optional)
7. End Connector
8. Nut
9. Cover O-Ring
10. End Connector O-Ring

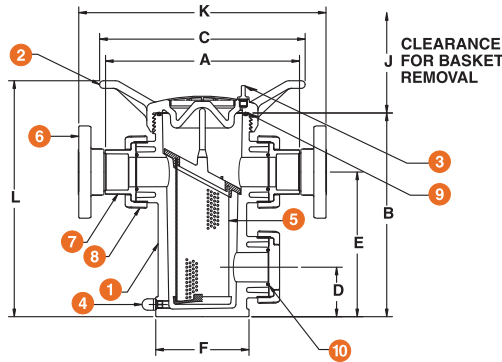

### OPERATING TEMPERATURE / PRESSURE

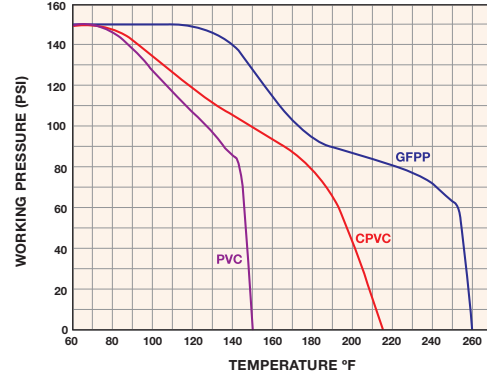

### DIMENSIONS – INCHES / MILLIMETERS

SIZE in / DN	A in / mm	B in / mm	C in / mm	D in / mm	E in / mm	F in / mm	J in / mm	K in / mm	L in / mm	WEIGHT lbs / kg		VOLUME gal / LT
										SOC / THD	FLANGED	
1/2 / 15	8.64 / 219	9.63 / 245	11.00 / 279	2.25 / 57	6.75 / 171	4.31 / 109	8.00 / 203	10.77 / 274	11.70 / 297	8.00 / 3.63	9.00 / 4.08	.20 / .76
3/4 / 20	8.64 / 219	9.63 / 245	11.00 / 279	2.25 / 57	6.75 / 171	4.31 / 109	8.00 / 203	11.02 / 280	11.70 / 297	8.00 / 3.63	9.00 / 4.08	.20 / .76
1 / 25	8.64 / 219	9.63 / 245	11.00 / 279	2.25 / 57	6.75 / 171	4.31 / 109	8.00 / 203	11.64 / 296	11.70 / 297	8.00 / 3.63	9.00 / 4.08	.20 / .76
1-1/4 / 32	12.75 / 324	13.38 / 340	13.50 / 343	3.25 / 83	9.50 / 241	6.13 / 156	12.86 / 327	15.63 / 397	15.50 / 394	14.00 / 6.35	16.50 / 7.48	.70 / 2.65
1-1/2 / 40	12.69 / 322	13.38 / 340	13.50 / 343	3.25 / 83	9.50 / 241	6.13 / 156	12.86 / 327	15.89 / 403	15.50 / 394	14.00 / 6.35	16.50 / 7.48	.70 / 2.65
2 / 50	12.75 / 324	13.38 / 340	13.50 / 343	3.25 / 83	9.50 / 241	6.13 / 156	12.86 / 327	16.29 / 413	15.50 / 394	14.00 / 6.35	16.50 / 7.48	.70 / 2.65
2-1/2 / 63	16.52 / 420	19.83 / 504	16.00 / 406	4.83 / 123	14.83 / 377	7.25 / 184	17.25 / 438	21.02 / 534	22.30 / 566	28.00 / 12.70	33.00 / 14.97	2.80 / 10.60
3 / 80	16.40 / 417	19.83 / 504	16.00 / 406	4.83 / 123	14.83 / 377	7.25 / 184	17.25 / 438	20.36 / 517	22.30 / 566	28.00 / 12.70	33.50 / 15.20	2.80 / 10.60
4 / 100	17.27 / 439	19.83 / 504	16.00 / 406	4.83 / 123	14.83 / 377	7.25 / 184	17.25 / 438	22.13 / 562	22.30 / 566	28.00 / 12.70	37.00 / 16.78	2.80 / 10.60

Dimensions are subject to change without notice – consult factory for installation information

### PRESSURE DROP CALCULATIONS

#### BASKET PERFORATION CORRECTION FACTORS

For 1/2" to 4" Strainers

Plastic		Stainless Steel	
1/32"	1.05	1/32"	.82
1/16"	1.00	20 Mesh	.79
1/8"	.58	40 Mesh	1.01
3/16"	.46	60 Mesh	1.20
		80 Mesh	1.16
		100 Mesh	1.20
		200 Mesh	1.09
		325 Mesh	1.22

#### PRESSURE LOSS CALCULATION FORMULA

The pressure drop across the strainer, for water or fluids with a similar viscosity, can be calculated using the formula at the right:

$$\Delta P = \left[ \frac{Q}{C_v} \right]^2$$

$\Delta P$  = Pressure Drop  
 $Q$  = Flow in GPM  
 $C_v$  = Flow Coefficient

### Cv VALUES

SIZE in / DN	Cv VALUES GPM	SIZE in / DN	Cv VALUES GPM
1/2 / 15	15	2 / 50	60
3/4 / 20	18	2-1/2 / 63	290
1 / 25	20	3 / 80	300
1-1/4 / 32	55	4 / 100	350
1-1/2 / 40	58		

The above Cv Values were determined using a 1/16" perforated plastic basket in 1/2" through 4" strainers.

To calculate pressure drop through vessels using other than 1/16" perforated baskets, first calculate the pressure drop using the listed Cv, and then multiply the result by the correction factor in the Correction Factors chart to the left.



Hayward is a registered trademark of Hayward Industries, Inc. © 2011 Hayward Industries, Inc.

– Eastar is a registered trademark of Eastman.  
 – Hastelloy is a registered trademark of Haynes International Inc.  
 – Monel is a registered trademark of Special Metals Corporation.